

HYTROL CONVEYOR COMPANY, INC.



Model A Aluminum Portable Narrow Belt Conveyor



The Model A, with its Roughtop belt, easily moves boxes, cases, and cartons up inclines. Its narrow width allows it to be used in a stairway for floor-to-floor conveying. It can be propped on a shelf for stacking or order picking. The Model A can be stored on its end in a minimum amount of space.

- Aluminum Bed
- Roughtop Belt
- Electrical Controls
- Reversible

1 Week Availability

ADJUSTMENT CHART FOR 8' TO 16' LONG UNITS								
Overall Length "A"	Angle of Incline	C = 19" With Roller Carriage			Angle of Incline	C = 34" With Roller Carriage		
		"D"	"E"	"F"		"D"	"E"	"F"
8'	8°	2'-7"	7'-10"	0'-3"	0°	2'-10"	8'-0"	0'-8"
	25°	4'-7"	7'-2"	0'-0"	25°	5'-11"	7'-2"	0'-8"
	30°	5'-7"	6'-10"	0'-2"	30°	6'-4"	6'-10"	0'-7"
	45°	6'-7"	5'-9"	0'-10"	43°	7'-8"	5'-10"	0'-3"
10'	8°	2'-10"	9'-10"	2'-3"	0°	2'-10"	10'-0"	2'-8"
	25°	5'-5"	9'-0"	1'-9"	25°	6'-8"	8'-11"	2'-6"
	30°	6'-1"	8'-7"	1'-6"	30°	7'-4"	8'-7"	2'-3"
	45°	7'-11"	7'-1"	0'-7"	43°	9'-0"	7'-4"	1'-9"
12'	8°	3'-2"	11'-10"	4'-3"	0°	2'-10"	12'-0"	4'-8"
	25°	6'-3"	10'-9"	3'-7"	25°	7'-7"	10'-9"	4'-3"
	30°	7'-1"	10'-3"	3'-3"	30°	8'-5"	10'-4"	4'-0"
	45°	9'-4"	8'-6"	2'-0"	43°	10'-4"	8'-10"	3'-2"
14'	8°	3'-5"	13'-11"	6'-3"	0°	2'-10"	14'-0"	6'-8"
	25°	7'-1"	12'-7"	5'-5"	25°	8'-5"	12'-7"	6'-1"
	30°	8'-1"	12'-1"	5'-0"	30°	9'-5"	12'-0"	5'-9"
	45°	10'-9"	10'-0"	3'-5"	43°	11'-9"	10'-3"	4'-8"
16'	8°	3'-8"	15'-11"	8'-2"	0°	2'-10"	16'-1"	8'-8"
	25°	8'-0"	14'-4"	7'-2"	25°	9'-3"	14'-4"	7'-2"
	30°	9'-1"	13'-9"	6'-8"	30°	10'-5"	13'-8"	7'-4"
	45°	12'-2"	11'-3"	4'-9"	43°	13'-1"	11'-8"	6'-1"

SIZE TO ORDER Overall Length "A"	"B"	WEIGHTS (Lbs.)
6'	1'-9 1/4"	145
8'	3'-9 1/4"	155
10'	5'-9 1/4"	165
12'	7'-9 1/4"	175
14'	9'-9 1/4"	195
16'	11'-9 1/4"	205
18'	13'-9 1/4"	215
20'	15'-9 1/4"	225

All weights in catalog are conveyor weights only. Accessories, crating, etc., are not included.

PORTABLES

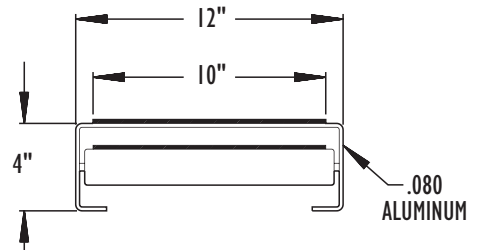
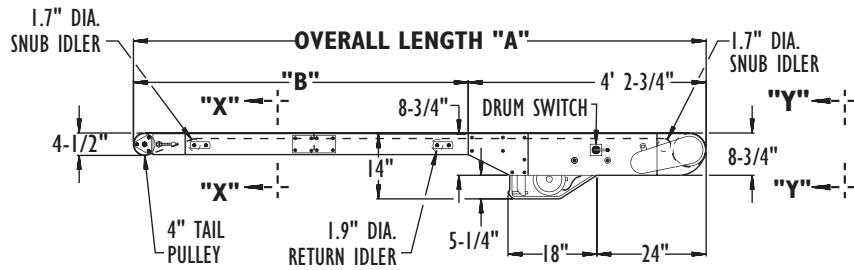

SECTION X-X

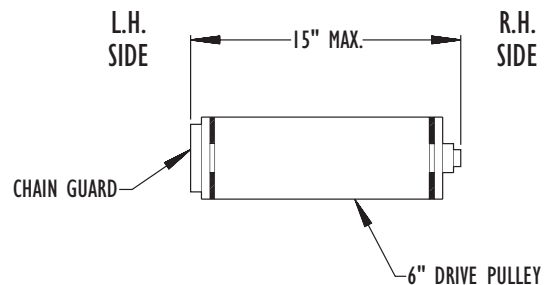
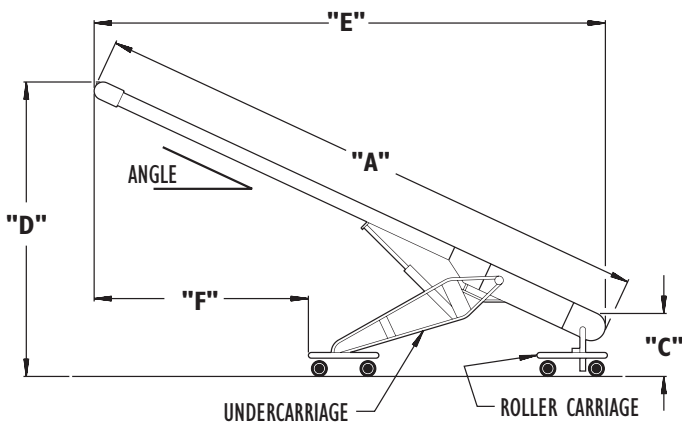

SECTION Y-Y



• Standard Specifications

Model **A**

BELT–10 in. wide Black Trackmate 120 Roughtop with PVC cover. Clipper lacing.

BED–12 in. wide x .080 aluminum, 6061–T6 heat treated, reinforced.

DRIVE PULLEY–6 in. dia. with 3/4 in. dia. shaft at bearings. Machine crowned and fully lagged.

TAIL PULLEY–4 in. dia. with 1 in. dia. shaft at bearings, machine crowned.

SNUB IDLER–Adjustable 1.7 in. dia. pre-lubricated ball bearings.

RETURN IDLER–Adjustable 1.9 in. dia. pre-lubricated ball bearings.

TAKE-UP–Take-ups provided at tail pulley. Provides 3-1/2 in. of belt take-up.

BEARINGS–Sealed, pre-lubricated ball bearings on drive and tail pulleys.

SPEED REDUCTION–4-step jackshaft V-belt and No. 40 roller chain.

MOTOR–1/2 HP–115/230V–1 Ph. 60 Hz. Totally Enclosed. Wired for 115 volt.

ELECTRICAL CONTROLS–Reversing drum switch with power cord and plug mounted on side shown on drawing. Specify if other side desired.

BELT SPEED–Constant 83 FPM.

CAPACITY–200 lbs. total distributed load, 120 lbs. unit load at 65 FPM.



REMOTE SWITCH CONTROL ROD



PERMANENT FLOOR STANDS



LOWER OR UPPER GRAVITY FEEDER



STAND WITH RUBBER WHEELS AND LOCKS

• Optional Equipment

CLEATED BELT–Two 1-1/2 in. dia. x 1/2 in. high cleats, fastened to belt by 5/16 in. elevator bolts spaced every 60 in. Requires gear reducer drive and spooled idlers.

BELT SPEED–Other constant and variable speeds. Requires gear reducer drive. NOTE: Capacity affected with speed change.

RUBBER WHEELS–Two 6 in. dia. x 2 in. wide with 5/8 in. dia. shaft.

STAND WITH RUBBER WHEELS–6 in. dia. x 2 in. wide wheels (with locks) mounted on adjustable tubular stand, 17 in. to 36 in. top of belt.

UNDERCARRIAGE–25 in. wide tubular steel frame with hydraulic adjustment mounted on support with 4 in. dia. steel swivel casters. See drawing and adjustment chart. Not available on 16 ft., 18 ft. & 20 ft. units.

ROLLER CARRIAGE–25 in. wide tubular steel support with 4 in. dia. steel swivel casters. See drawing and adjustment chart. Not available on 16 ft., 18 ft. & 20 ft. units.

FLOOR SUPPORTS–Adjustable steel channel with knee braces. MSAT on tail RSAD on drive.

GRAVITY CONVEYOR BRACKET–1/2 in. dia. rod for connecting wheel or roller conveyor.

LOWER GRAVITY FEEDER–2 ft. long x 12 in. wide (1-1/2SW-12-24) includes adjustable tubular support and gravity conveyor bracket.

UPPER GRAVITY FEEDER–2 ft. long x 12 in. wide (3SW-12-16) includes adjustable tubular support and gravity conveyor bracket.

LOWER POWERED FEEDER–Chain type driven from drive pulley. 2 ft. long belt feeder section includes adjustable tubular support and gravity conveyor bracket.

GUARD RAILS–Channel type, adjustable vertically and horizontally.

STAIRWAY WALL BRACKETS–Hinged brackets bolt to bed section and wall. Adjustable leg to rest on floor or step. Hook to hold conveyor close to wall when not in use.

TROUGHING ATTACHMENT–Flat steel supports under belt form trough for handling loose material. Hopper available.

STAINLESS STEEL BED COVER–18 ga. stainless steel skin (for ice house application).

SELF-CLEANING DRIVE & TAIL PULLEYS–Crowned and ribbed to prevent clogging under belt.

GEAR REDUCER DRIVE–Sealed worm gear speed reducer driven by motor with V-belt. Drive is bolted to bottom of bed. Standard motor support and guard not available. Affects mounting of other options. Consult factory.

REMOTE SWITCH CONTROL–Rod running length of conveyor to operate reverse drum switch from both ends. Switch regularly furnished on side shown on drawing. Specify if required on other side.

MOTORS–1/2 HP maximum.