

HYTROL CONVEYOR COMPANY, INC.

Model **PSB** Plastic Belt Conveyor

The Model PSB with modular plastic belting uses a positive drive system to eliminate belt slippage and mistracking.

- 16 Belt Widths
- Polypropylene 2" Pitch Plastic Belt
- Adjustable MS-Type Floor Supports Available



Conveyor shown with optional floor supports

| SIZE TO ORDER Overall Length | Belt Width | 8" | 10" | 12" | 14" | 16" | 18" | 20" | 22" | 24" | 26" | 28" | 30" | 32" | 34" | 36" | 38" |
|---------------------------------|---------------------|-----|-----|-----|-----|-----|-----|-----|-----|-----|-----|-----|-----|-----|-----|-----|-----|
| | Between Rail Width | 9" | 11" | 13" | 15" | 17" | 19" | 21" | 23" | 25" | 27" | 29" | 31" | 33" | 35" | 37" | 39" |
| | Overall Frame Width | 12" | 14" | 16" | 18" | 20" | 22" | 24" | 26" | 28" | 30" | 32" | 34" | 36" | 38" | 40" | 42" |
| 10' | Weights | 328 | 248 | 368 | 388 | 408 | 428 | 448 | 468 | 488 | 508 | 528 | 548 | 568 | 588 | 608 | 628 |
| | Weights Per Foot | 18 | 20 | 22 | 24 | 26 | 28 | 30 | 32 | 34 | 36 | 38 | 40 | 42 | 44 | 46 | 48 |

| LOAD CAPACITY CHART @ 65 FPM | |
|------------------------------|--------------------------|
| HP | 16" TO 28" OVERALL WIDTH |
| | TOTAL LOAD (LBS.) |
| | UP TO 50' |
| 1/2 | 750 |
| 1 | 1750 |
| 2 | 3750 |

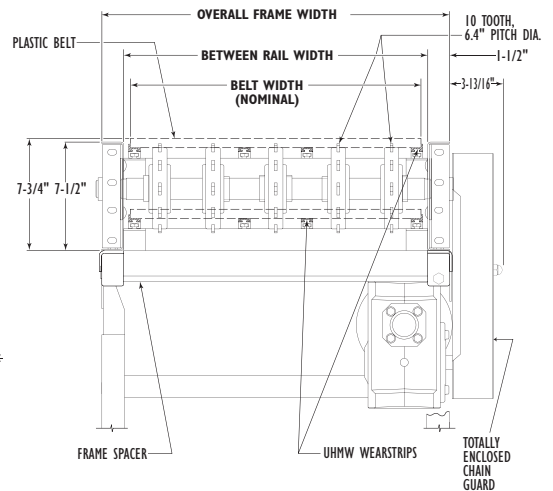
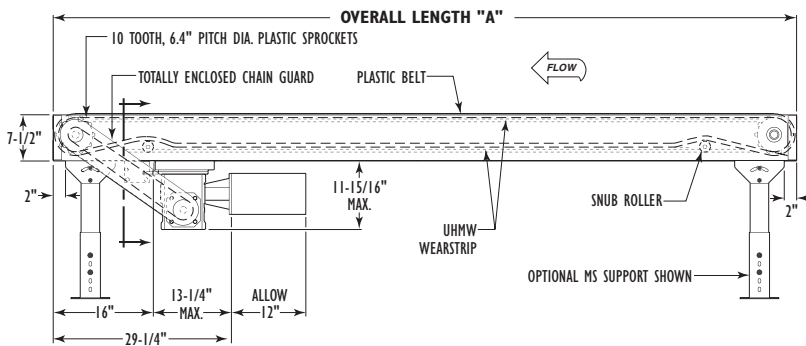

SECTION X-X

• Standard Specifications

END DRIVE—Located on discharge end of conveyor. Chain guard located on left hand side.

BELT—Polypropylene 2 in. pitch Flush Grid, nominal 1 in. less than BR.

BED—UHMW on aluminum slider bars, mounted to frame spacers. Mounted in 7-1/2 in. x 12 ga. powder painted, formed steel channel frame bolted together with butt couplings.

CROSS BRACING—Rods with turnbuckles are fastened to underside of bed to provide alignment of bed sections to insure correct belt tracking. Supplied on every other section 30 ft. bed lengths and over.

DRIVE AND TAIL SPROCKETS—10 tooth 6.4 in. pitch dia. molded plastic sprockets on 1-1/2 in. sq. shaft, 1-3/16 in. dia. shaft at bearings.

SNUB ROLLERS—Located at drive and tail ends.

RETURN BARS—UHMW on aluminum.

BEARINGS—Sealed, pre-lubricated, self-aligning ball bearings on drive and tail shafts.

SPEED REDUCTION—Sealed worm gear C-Face speed reducer. No. 50 roller chain to drive sprocket.

MOTOR—1/2 HP-208/230/460/575V-3 Ph. 60 Hz. Totally Enclosed C-Face.

BELT SPEED—Constant 65 FPM.

CAPACITY—Maximum load per linear foot of conveyor 200 lbs. NOT TO EXCEED capacity in chart.

• Optional Equipment

FLOOR SUPPORTS—MS Type floor supports are available with a wide range of adjustment. Specify top of belt or roller elevation. One support required at every bed joint and ends of conveyor. Holes in feet for lagging to floor. Knee braces recommended above MS-6 support.

BED—Stainless steel in lieu of powder painted HRS (Excluding Aluminum Support Bars).

BELT—Other belts available, contact factory.

BELT SPEED—Other constant and variable speeds. V-belt drive supplied on speeds under 15 FPM and with variable speeds. NOTE: Capacity affected with speed change.

V-BELT DRIVE—V-Belt supplied between motor and reducer.

O-RING DRIVE CHAIN—With sealed in lubricant (Recommended for applications that do not permit regular lubrication).

CEILING HANGARS—5/8 in. dia. x 8 ft. long unplated rods fully threaded. Other lengths and galvanized rods available.

NOSEOVER AND NOSEUNDER—Can be incorporated to provide continuous belt travel from horizontal to incline or decline.

MOTORS—Energy efficient, single phase, brakemotor, other characteristics. 2 HP maximum.

ELECTRICAL CONTROLS—One direction magnetic starters and push-button stations. AC Variable Frequency Drive.

MISCELLANEOUS