

# HYTROL CONVEYOR COMPANY, INC.

## Model **SL** Heavy Duty Horizontal Slat Conveyor

The Model SL Steel Belt Slat conveyor provides lasting, dependable performance. Can be used to convey hot, oily parts or items through heat drying processes. Can also be used for assembly line and production operations.

- 4 Bed Widths
- Energy Efficient Motor with AC Variable Speed Controller
- Rugged—all Steel Construction
- Modular Construction
- Roller Chain Reduces Friction
- Adjustable SLS-Type Floor Supports Available

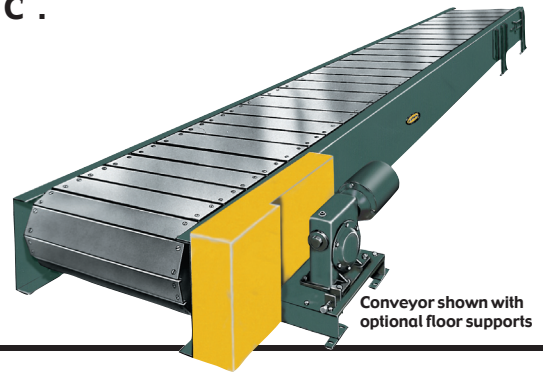

Conveyor shown with optional floor supports



SIZE TO ORDER Overall Length "A"	Bed Length "L"	Slat Width	31"	37"	43"	49"
		Overall Bed Width	36"	42"	48"	54"
9'	-	WEIGHTS (Lbs.)	1773	1936	2099	2262
14'	5'		2291	2506	2721	2936
19'	10'		2809	3076	3343	3610
24'	15'		3327	3646	3965	4284
29'	20'		3845	4216	4587	4958
39'	30'		4881	5357	5831	6306
49'	40'		5917	6497	7075	7654
59'	50'		6954	7638	8319	9003
69'	60'		7990	8778	9563	10351
79'	70'		9026	9918	10807	11669

All weights in catalog are conveyor weights only. Accessories, crating, etc., are not included.

MISCELLANEOUS

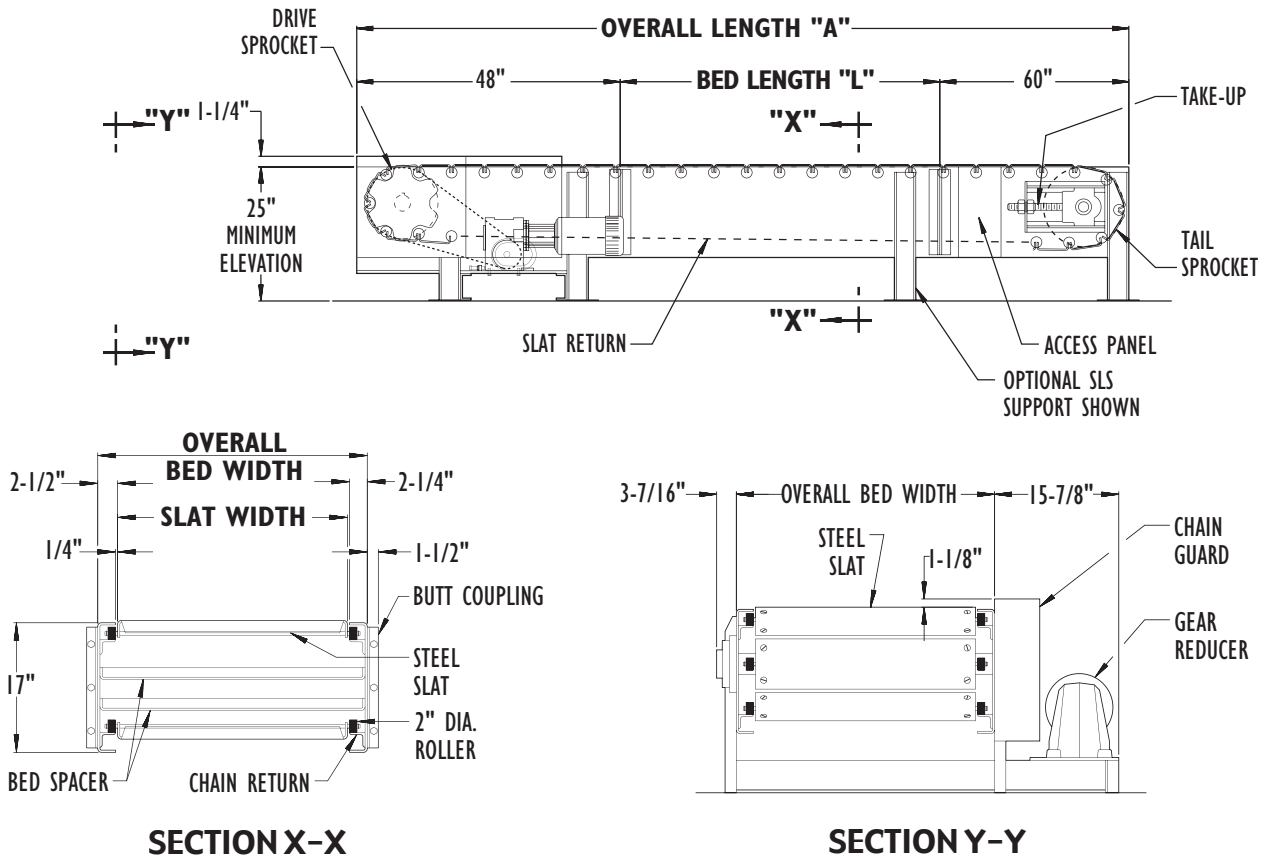

# • Standard Specifications

Model **SL**

**END DRIVE**—Located at discharge end of conveyor. Chain guard located on left hand side.

**SLATS**—Formed steel slat, 5-3/4 in. x 1-1/2 in. x 7 ga. channel.

**CHAIN**—6 in. pitch bushed roller steel chain with 2 in. dia. high capacity roller bearing.

**BED**—17 in. deep x 10 ga. formed steel channel powder painted. Standard 5 ft. and 10 ft. long sections bolt together with butt couplings.

**DRIVE SPROCKETS**—12 in. pitch dia. with 2-15/16 in. dia. shaft.

**TAKE-UP**—Take-ups provided at tail sprockets. Provides 15-1/2 in. of chain take-up.

**BEARINGS**—Sealed, pre-lubricated, self-aligning, ball bearings at drive and tail sprockets.

**SPEED REDUCTION**—Heavy-duty sealed worm gear C-Face speed reducer. No. 100 roller chain to drive sprocket.

**MOTOR**—2 HP-230/460V-3 Ph. 60 Hz. Energy Efficient C-Face and MD65 AC variable speed controller with soft start capability and motor overload protection.

**CONVEYING SPEED**—Constant 30 FPM.

**CAPACITY**—Maximum load per linear foot of conveyor 1 400 lbs. NOT TO EXCEED capacity in chart.

**FLOOR SUPPORTS**—Now supplied as optional equipment.

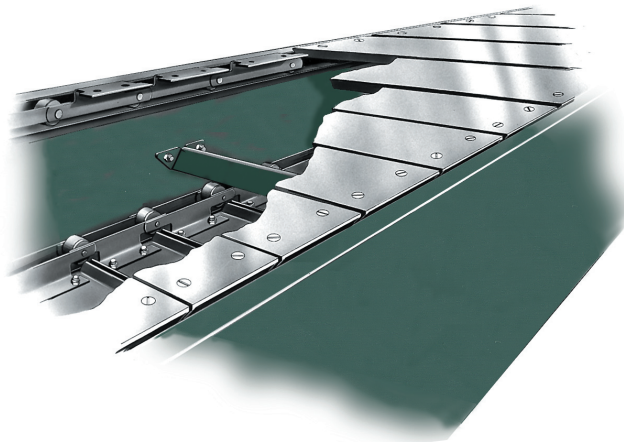

Detail shows inside view of roller chain which carries steel slats. Chain rides on steel angle mounted to conveyor side of channel.

LOAD CAPACITY CHART @ 30 FPM						
HP	SLAT WIDTH			SLAT WIDTH		
	31" & 37"			43" & 49"		
	TOTAL LOAD (LBS.)			TOTAL LOAD (LBS.)		
	UP TO 24'	UP TO 49'	UP TO 79'	UP TO 24'	UP TO 49'	UP TO 79'
2	2400	850	-	2000	-	-
3	6000	4400	2900	5600	3600	1700

# • Optional Equipment

**FLOOR SUPPORTS**—SLS and SLSD Type fixed floor supports are available. Specify top of slat elevation. One support required at every bed joint and ends of conveyor. Holes in feet for lagging to floor.

**SLAT**—Wood, contact factory.

**MECHANICAL SHEAR PIN HUBS** – Required if MD65 Controller is not used.

**ELECTRONIC SHEAR PIN** – Required if MD65 Controller is not used.

**CONVEYING SPEED**—Other constant and variable speeds available. NOTE: Capacity affected with speed change. Contact Factory.

**MOTORS**—3 HP maximum.

**ELECTRICAL CONTROLS**—Push-button stations.

Our Vision: To be the finest conveyor distributor in the hearts and minds of the people we serve.

**McKESOCK ENGINEERING Ltd.**

7-138 Anderson Avenue, Markham, L6E 1A4  
 Phone: 905-471-0420, Fax: 905-471-6617  
 Email: sales@mckessockconveyors.com  
 www.mckessockconveyors.com

