

The **CHAIN DRIVEN ZONE ACCUMULATION** conveyor is a zero pressure, chain driven live roller conveyor designed to carry loads such as pallets, drums, etc. This unit is designed for zero pressure accumulation, reducing the possibility of product damage.

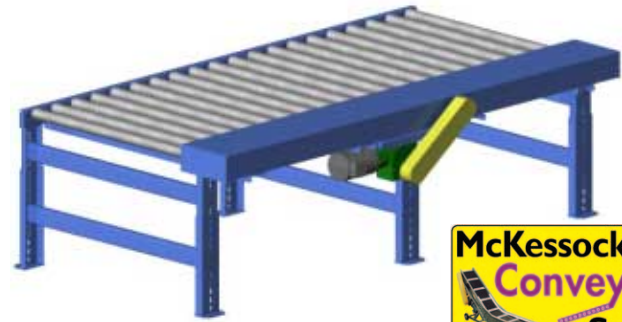

STANDARD SPECIFICATIONS

Roller Centers: 4.00" with 40A21 sprockets.
 4.50" with 60A15 sprockets.
 5.00" with 50A19 sprockets.
 6.00" with 60A16 sprockets.
 7.50" with 60A16 sprockets.
 12.00" with 60A16 sprockets.

Effective Widths: 13", 19", 25", 31", 37", 43", 49", 54", 57" and 61". Also available from 6" to 61" in 1" increments.

Lengths: Even increments of the roller centers up to 75'. Length also limited to 75 rollers on each side of the drive.

Standard Zones: 60" Long. Also available from 48" to 72" in increments equal to the roller centers. Each zone is controlled by one sensor with self contained logic.

Drive: Standard D16 - side, bottom, near center with live axle drive roller. Drive has cast iron worm gear speed reducer with a standard M03 3/4 H.P. 230/460 TEFC motor.

Electrical Requirements: 24v control voltage in addition to selected motor voltage.

Speed: Standard 30 feet per minute. Also available from 10 to 120 feet per minute.

Rollers: Standard 2511; 2.5 dia., 11 ga. wall tubes with 11/16 hex cold rolled steel axle, spring retained. Standard A51 bearing are grease packed.

Frames: Standard F78 6" deep x 3/16" formed steel on chain box side, 4" x 1-1/2" x 3/16" channel roller set high on idler side with bolted 5" x 1-1/2" x 3/16" crosstie.

Chain Covers: 1/8" steel with two piece construction for easy access to chain loops.

Pneumatic Clutch: A Standard Ball bearing pilot, end of shaft mount, multiple drive clutch.

Air Requirement: 80 PSI

Supports: SPHH style adjustable set for standard 36" top of rollers located on nominal 5' centers. Also available from 11" to 42" top of roller at no additional charge.

Capacity: Up to 1,000 lbs. per lineal foot of conveyor with supports on 5' centers. Several factors affect conveyor capacity. Consult factory to evaluate specific applications.

Guard Rails: Standard G99: No Guard Rail.

Roll Covers: Standard V98: No Roll Cover.

Finish: Standard P94: Safety Blue, Epoxy Powder Coat.

STANDARD D16 - SIDE, BOTTOM, NEAR CENTER

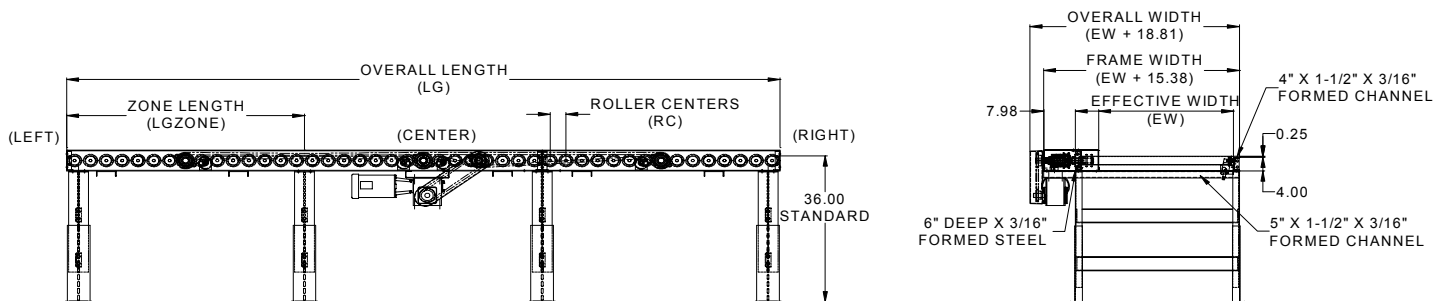

D17 - SIDE, BOTTOM, NEAR LEFT END
D18 - SIDE, BOTTOM, NEAR RIGHT END

Our Vision: To be the finest conveyor distributor in the hearts and minds of the people we serve.



7-138 Anderson Avenue, Markham, L6E 1A4
 Phone: 905-471-0420, Fax: 905-471-6617
 Email: sales@mckessockconveyors.com
 www.mckessockconveyors.com



DRIVE OPTIONS

	<p>D10 - BOTTOM, LOCATED NEAR CENTER</p> <p>D11 - BOTTOM, LOCATED NEAR END, LEFT</p> <p>D12 - BOTTOM, LOCATED NEAR END, RIGHT</p>
	<p>D13 - TOP, LOCATED NEAR CENTER</p> <p>D14 - TOP, LOCATED NEAR LEFT END</p> <p>D15 - TOP, LOCATED NEAR RIGHT END</p>

MOTOR SELECTION CHART

Horizontal CHAIN CONVEYOR @ 30 FPM

H.P.	3/4	1	1-1/2	2
Total Load (Lbs.) Up to 50'	5,500	7,330	11,000	14,675

Horizontal CHAIN CONVEYOR @ 45 FPM

H.P.	3/4	1	1-1/2	2
Total Load (Lbs.) Up to 50'	3,650	4,890	7,350	9,780

Horizontal CHAIN CONVEYOR @ 60 FPM

H.P.	3/4	1	1-1/2	2
Total Load (Lbs.) Up to 50'	2,750	3,675	5,500	7,340

OPTIONAL COMPONENTS

DRIVE	D16 ; D10, D11, D12, D13, D14, D15, D17, D18, D99
FRAME	F78 ; F79
GUARD RAIL	G99 ; G82, G83
MOTOR	M03 ; M01, M02, M04, M05, M06, M07, M08, M09, M10, M11, M12, M13, M14, M15, M16, M17, M19, M20, M21, M22, M23, M24, M25, M26, M27, M30, M31, M32, M33, M34, M97, M98, M99
ROLLER BEARING	A51 ; A53, A55, A59, A60, A62
ROLLER COVER	V98 ; V11, V42, V73
SUPPORT CENTER	SCC5 ; SCC0, SCC10
FINISH	P94 ; P09, P11, P24, P45, P95

*For descriptions of **OPTIONAL COMPONENTS** see pages 170-176.

AVAILABLE ACCESSORIES

- Top of roller heights can be above listed range. Specify when ordering.
- Electrical Controls: magnetic starter, combination starter, DC variable speed drives. Lanyard emergency switch, photo-eye and various part sensors.
- Stainless steel construction.

HOW TO ORDER

CDZA25 - EW - RC - LG - SP - LG ZONE - BE - EE - DRIVE - FRAME - GDRAIL - MOTOR - RLBRG - ROLCV - SUPCC - FINISH

EXAMPLE: CDZA25-13-4-120-30-60-36-36-D16-F78-G99-M03-A51-V98-SCC5-P94



Our Vision: To be the finest conveyor distributor in the hearts and minds of the people we serve.

7-138 Anderson Avenue, Markham, L6E 1A4
 Phone: 905-471-0420, Fax: 905-471-6617
 Email: sales@mckessockconveyors.com
 www.mckessockconveyors.com

