

The **Medium Duty Roller Bed Belt Conveyor** is designed to convey heavier products. Roller bed design provides for greater capacity by reducing the friction on the belt. Can be used for testing, sorting and assembly line operations.



### STANDARD SPECIFICATIONS

**Belting:** Standard B98 PVC-120 black, covered one side. Belt is shipped laced and installed on conveyors up to 10' long. On all other conveyors the belt is shipped loose with lacing installed for field installation.

**Belt Widths:** Standards widths are 12", 18", 24", 30", 36", 42" and 48". Also available from 12" to 48" in 1" increments.

**Roller Center:** 3", 4.5", and 6"

**Lengths:** 5' to 100' in 1" increments.

**Drive:** Standard D08 - end, right hand side. Drive has cast iron worm gear speed reducer with Standard M99 1/2 H.P. 230/460 volt TEFC motor.

**Speed:** Standard 60 feet per minute. Also available from 3 to 150 fpm

**Bearings:** Sealed pre-lubricated, cast iron flange ball bearings.

**Bed:** 6-1/2 x 1-1/2 x deep x 1/8" formed steel channel. The belt is supported by rollers. 1.9" dia., 16 ga. wall tubes with 7/16" hex cold rolled steel axle spring retained. Standard A11 bearings are grease packed.

**Drive Pulley:** Standard 4" dia. with 1-3/16" dia. shaft crowned and lagged. Mounted in 2 bolt flange bearings. Conveyors 51' and longer will be supplied with 8" dia. pulley with 1-7/16" dia. shaft crowned and lagged.

**Take-up Pulley:** Standard 4" dia. with 1-3/16" dia. shaft, crowned, mounted in 2 bolt flange bearings.

**Return Rollers:** 1.9" dia., 16 ga. wall tubes with 7/16" hex cold rolled steel axle spring retained. Standard A11 bearings are grease packed.

**Snubber Rollers:** Standard 1.9 dia. 12 ga. wall tubes with 7/16" hex cold rolled steel axle, spring retained. Standard A23 bearings are grease packed with front and back seals. 2.5 dia. 11 ga. wall tubes with 11/16" hex cold rolled steel axle, spring retained. Standard A55 bearings are grease packed with front and back seals. Used on conveyors with D02 & D03 Center drive.

**Supports:** SPH style adjustable set for a Standard 36" top of conveyor located on nominal 10' centers. Also available from 7.5" to 42" top of belt at no additional charge.

**Guard Rail:** Standard G99: No Guard Rail.

**Finish:** Standard P94: Safety Blue, Epoxy Powder Coat.

### STANDARD D08 - END, RIGHT HAND SIDE

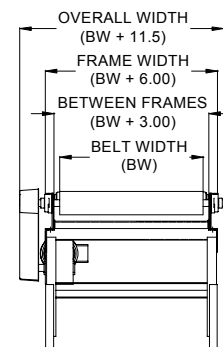
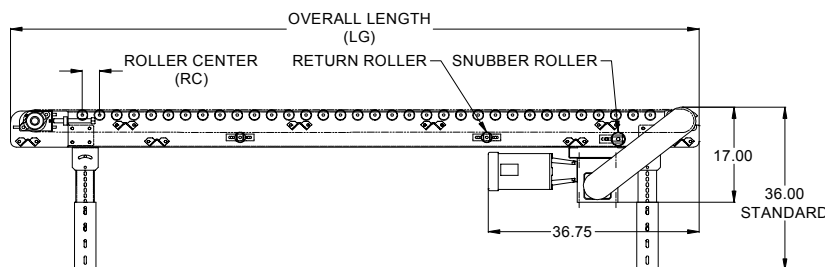

### DRIVE OPTIONS

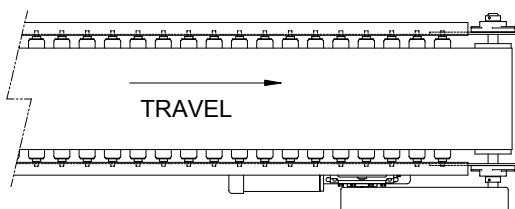

STANDARD D08 - END, RIGHT HAND SIDE

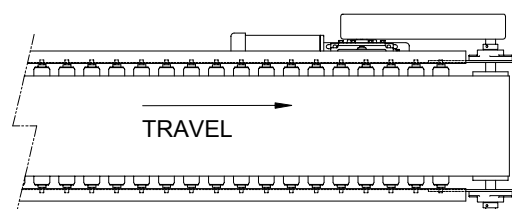

D01 - END, LEFT HAND SIDE

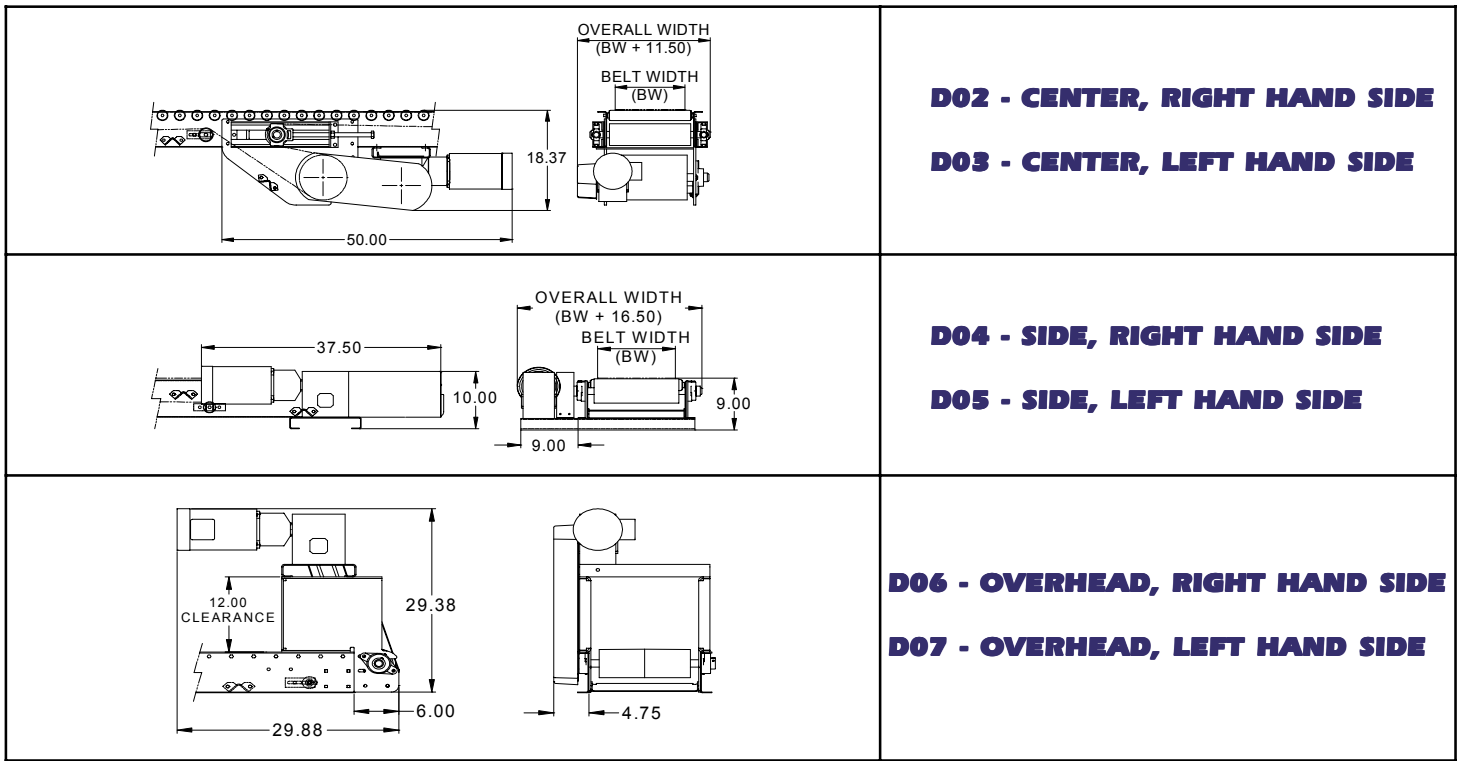

**D02 - CENTER, RIGHT HAND SIDE**

**D03 - CENTER, LEFT HAND SIDE**

**D04 - SIDE, RIGHT HAND SIDE**

**D05 - SIDE, LEFT HAND SIDE**

**D06 - OVERHEAD, RIGHT HAND SIDE**

**D07 - OVERHEAD, LEFT HAND SIDE**

### MOTOR SELECTION CHART

Horizontal MDRB @ 60 FPM

H.P.	1/2	3/4	1	1-1/2	2
Total Load (Lbs.)	1300	2000	2500	3200	3900

### OPTIONAL COMPONENTS

<b>BELT</b>	<b>B98</b> ; B01, B02, B03, B04, B05, B06, B97, B99
<b>DRIVE</b>	<b>D08</b> ; D01, D02, D03, D04, D05, D06, D07, D41, D44, D45, D46
<b>GUARD RAIL</b>	<b>G99</b> ; G31, G32, G33, G34, G35, G36, G37, G38, G39, G40
<b>MOTOR</b>	<b>M99</b> ; M01, M02, M03, M04, M05, M06, M07, M08, M09, M10, M11, M12, M13, M14, M15, M16, M17, M19, M20, M21, M22, M23, M24, M25, M26, M27, M30, M31, M32, M33, M34, M97, M98
<b>ROLLER BEARING</b>	<b>A11</b> ; A13, A18,A21, A23, A31, A33
<b>SUPPORT CENTER</b>	<b>SCC10</b> ; SCC0, SCC5
<b>FINISH</b>	<b>P94</b> ; P09, P11, P24, P45, P95, P99

\*For descriptions of **OPTIONAL COMPONENTS** see pages 170-176.

## AVAILABLE ACCESSORIES

- Electrical Controls: magnetic starter, combination starter, DC variable speed drives. Lanyard emergency switch, photo-eye and various part sensors.
- Top of belt heights can be above listed range please specify when ordering.
- Side Tables: One or both sides.
- Stainless steel construction.

### HOW TO ORDER

MDRB - BW - RC - LG - SP - BE - EE - BELT - DRIVE - GDRAIL - MOTOR - RLBRG - SUPCC - FINISH

**EXAMPLE:** MDRB-12-3-120-60-36-36-B98-D08-G99-M99-A11-SCC10-P94



Our Vision: To be the finest conveyor distributor in the hearts and minds of the people we serve.

7-138 Anderson Avenue, Markham, L6E 1A4  
 Phone: 905-471-0420, Fax: 905-471-6617  
 Email: sales@mckessockconveyors.com  
 www.mckessockconveyors.com

