



The **Multi-Strand Chain Conveyor** is a drag chain conveyor used on pallets that have bottom designs not conveyable on roller conveyors. Its design is suitable for extreme environments because of the low number of moving parts and limited amount of required maintenance.



### STANDARD SPECIFICATIONS

**Number of strands:** 2, 3, or 4.

**Center to Center of Chains:** Standard centers are 12", 18", 24", 30", 36", 42" and 48". Also available in centers from 6" to 54".  
Note: Limited to 84" overall width.

**Lengths:** 3' to 20' in 1" increments.

**Drive:** Standard D35-end, right hand side, MSCC. Drive has a cast iron worm gear speed reducer with a standard M03 3/4 H.P. 230/460 TEFC motor.

**Speed:** Standard 30 feet per minute. Also available from 2 to 60 fpm.

**Bearings:** Sealed pre-lubricated, cast iron flange ball bearing.

**Roller Chain:** Standard RC#80 guided by 1/4" x 1/2" track.

**Frames:** 3/16" formed steel with bolted 5" x 1-1/2" x 3/16" crossties.

**Drive Sprocket:** 7.027" Pitch Dia, Steel on a 1-7/16" shaft mounted in 2 bolt flange bearing.

**Take-Up Sprocket:** 3.864" Pitch Dia, Steel with internal ball bearing mounted on a 3/4" shaft.

**Supports:** SPHH style adjustable set for standard 36" top of chain located on nominal 10' centers. Also available from 10" to 42" top of chain at no additional charge.

**Guard Rail:** Standard G99: No Guard Rail

**Finish:** Standard P94: Safety Blue, Epoxy Powder Coat.

### STANDARD D35-END, RIGHT, HAND SIDE, MSCC

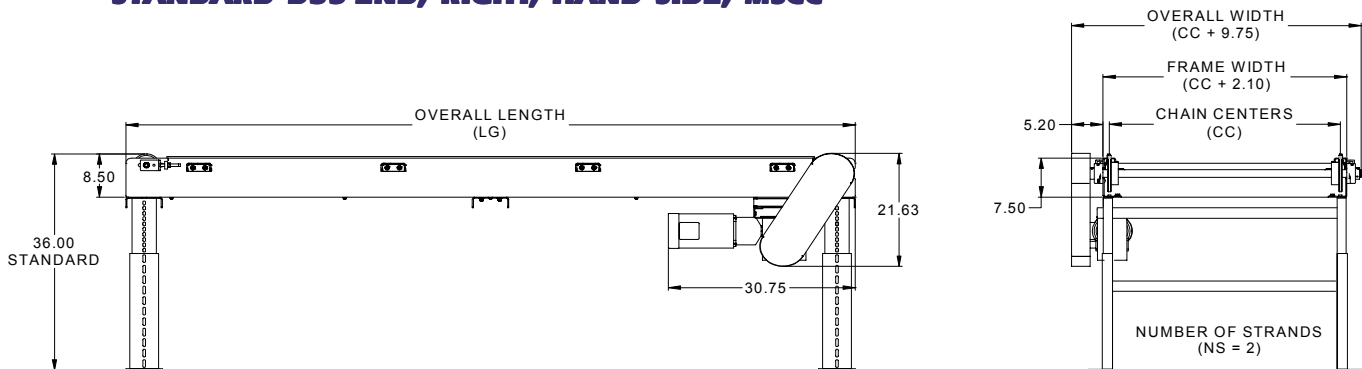

### DRIVE OPTIONS

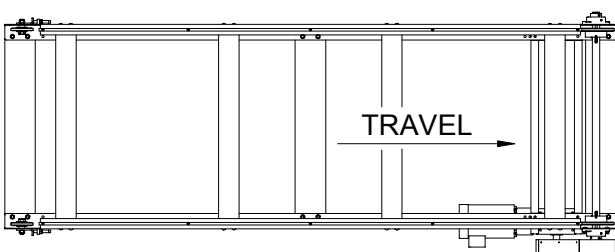

**STANDARD D35-END, RIGHT HAND SIDE, MSCC**

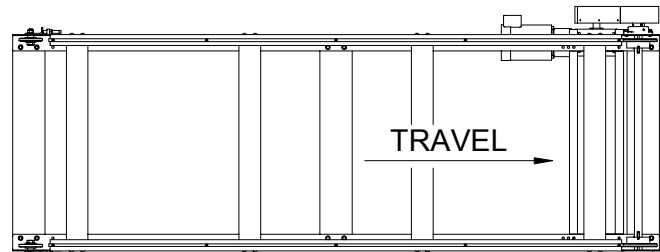

**D32-END, LEFT HAND SIDE, MSCC**

## DRIVE OPTIONS

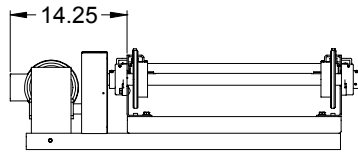
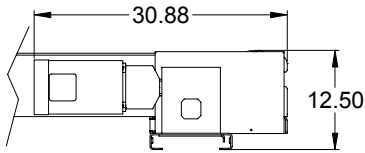

**D33-SIDE, RIGHT HAND, MSCC**

**D34-SIDE, LEFT HAND MSCC**

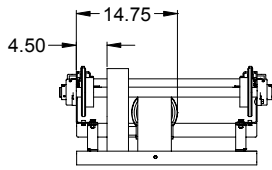
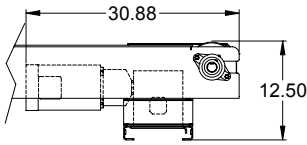

**D30-END, LOCATED BETWEEN STRANDS**

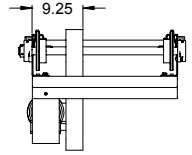
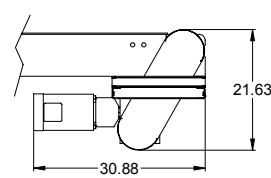

**D31-END, BETWEEN STRANDS, BELOW FRAME**

## STRAND OPTIONS

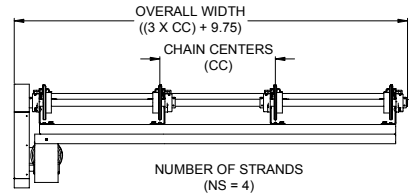
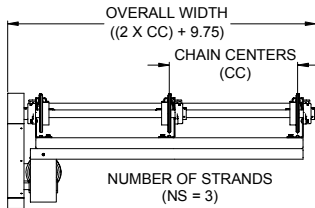

## MOTOR SELECTION CHART

### Horizontal CHAIN CONVEYOR @ 30 FPM

H.P.	3/4	1	1-1/2	2
Total Load (Lbs.)	1,850	2,400	3,200	4,100

### Horizontal CHAIN CONVEYOR @ 40 FPM

H.P.	3/4	1	1-1/2	2
Total Load (Lbs.)	1,350	1,750	2,300	3,000

### Horizontal CHAIN CONVEYOR @ 60 FPM

H.P.	3/4	1	1-1/2	2
Total Load (Lbs.)	900	1,200	1,600	2,000

## OPTIONAL COMPONENTS

<b>DRIVE</b>	<b>D35;</b> D30, D32, D33, D99
<b>GUARD RAIL</b>	<b>G99;</b> G41, G42, G43
<b>MOTOR</b>	<b>M03;</b> M01, M02, M04, M05, M06, M07, M08, M09, M10, M11, M12, M13, M14, M15, M16, M25, M26, M27, M28, M31, M32, M33, M34, M99, M100, M101, M102, M103, M104, M105, M106, M107, M108M109
<b>SUPPORT CENTER</b>	<b>SCC10;</b> SCC0, SCC5
<b>FINISH</b>	<b>P94;</b> P09, P11, P24, P45, P94, P95, P99

\*For descriptions of **OPTIONAL COMPONENTS** see pages 170-176.

## AVAILABLE ACCESSORIES

- Electrical Controls: magnetic starter, combination starter, DC variable speed drives. Lanyard emergency switch, photo-eye and various part sensors.
- Stainless steel construction.
- Walkover plates

## HOW TO ORDER

MSCC - NS - CC - LG - SP - BE - EE - DRIVE - GDRAIL - MOTOR - SUPCC - FINISH

**EXAMPLE:** MSCC-2-12-120-30-36-36-D35-G99-M03-SCC10-P94



Our Vision: To be the finest conveyor distributor in the hearts and minds of the people we serve.

7-138 Anderson Avenue, Markham, L6E 1A4  
 Phone: 905-471-0420, Fax: 905-471-6617  
 Email: sales@mckessockconveyors.com  
 www.mckessockconveyors.com

